

RocPlane

Planar sliding stability analysis for rock slopes

Sample Problems

TABLE OF CONTENTS

ROCPLANE SAMPLE PROBLEM #1	4
Derive the factor of safety equation, ignoring then considering cohesion	
ROCPLANE SAMPLE PROBLEM #2	6
a) Derive factor of safety, vertical slope	
b) Calculate factor of safety, confirm with RocPlane	
c) Calculate length of slope resulting in failure	
d) Determine factor of safety, water pressure present	
e) Sensitivity analysis, factor of safety vs. water percent filled	
f) Determine probability of failure, varying drainage scenarios	
ROCPLANE SAMPLE PROBLEM #3	14
a) Determine factor of safety, varying cohesion and friction angle	
b) Determine factor of safety, water filled tension crack present	
c) Calculate the distance from tension crack to slope crest	
d) Optimize cable orientation and tension, given earthquake loading, slope saturation, and factor of safety	
ROCPLANE SAMPLE PROBLEM #4	19
Calculate required bolt force given factor of safety	
ROCPLANE SAMPLE PROBLEM #5	21
a) Determine factor of safety, tension crack present and not present	
b) Calculate distance from tension crack to slope crest	
c) Determine bolts required to stabilize the slope given a factor of safety	
ROCPLANE SAMPLE PROBLEM #6	26
Sensitivity analysis on cohesion, friction angle, failure plane angle and percent tension crack filled with water	
ROCPLANE SAMPLE PROBLEM #7	30
a) Determine factor of safety, external load present	
b) Calculate capacity of bolt required to stabilize slope given a factor of safety	
ROCPLANE SAMPLE PROBLEM #8	32
a) Determine factor of safety of benches in an open pit	
b) Determine overall pit slope angle, comment on the overall pit wall stability	
c) Calculate maximum bench width given a factor of safety	
d) Determine probability of failure, cohesion and friction angle as random variables	
e) Discuss sampling methods and number of samples used	
f) Determine factor of safety with correlated random variables	
ROCPLANE SAMPLE PROBLEM #9	39
a) Determine factor of safety, before and after excavation	

b) Prove safety factor is independent of upper slope angle

ROCPANE SAMPLE PROBLEM #10 42

 a) Using the Point Estimation Method, determine the expected values and coefficient of variation

 b) Calculate the Probability of Failure

REFERENCES..... 45

ROCPLANE SAMPLE PROBLEM #1

Derive an equation for the factor of safety of the dry planar wedge shown below
a) first ignoring cohesion, then b) incorporating cohesion. Include the influence of friction at the joint surface in both equations.

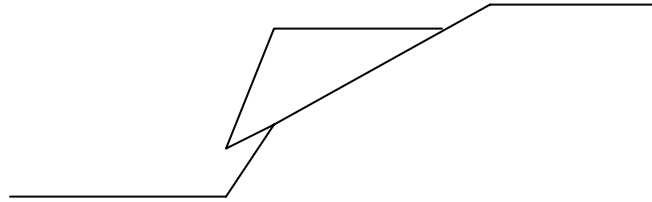

SOLUTION:

Define the positive direction as the direction of sliding

$$\text{Factor of Safety} = \frac{\text{resisting forces}}{\text{driving forces}}$$

a) No Cohesion:

W = weight of the planar wedge

N = normal force

θ = angle of incline

ϕ = angle of friction

$$\text{driving force} = W \sin \theta$$

$$\begin{aligned} \text{resisting force} &= N \tan \phi \\ &= W \cos \theta \tan \phi \end{aligned}$$

$$FS = \frac{W \cos \theta \tan \phi}{W \sin \theta} = \frac{\tan \phi}{\tan \theta}$$

∴ For the simple case of no cohesion and no water pressure, the Factor of Safety against sliding is simply given by the ratio of $\tan \phi / \tan \theta$.

b) Incorporating Cohesion:

$$\text{driving force} = W \sin \theta$$

$$\text{shear stress} = \tau = c + \sigma_n \tan \phi$$

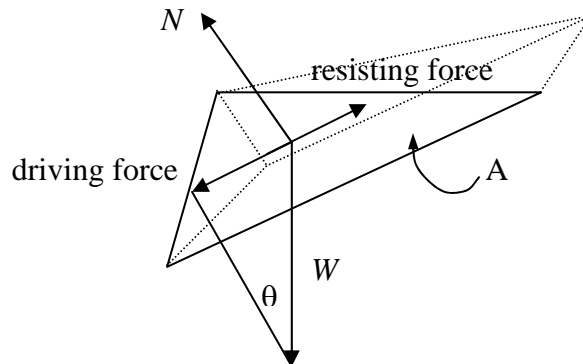

$$\Rightarrow \text{resisting force} = T = cA + \sigma_n A \tan \phi$$

; where A is the contact area of the wedge with the failure plane
and c is the cohesive strength of the joint surface

$$\text{Since } \sigma_n = \frac{N}{A} \text{ and } N = W \cos \theta$$

$$\text{resisting force} = cA + W \cos \theta \tan \phi$$

$$FS \frac{cA + W \cos \theta \tan \phi}{W \sin \theta}$$

ROCPANE SAMPLE PROBLEM #2

a) For the rock slope shown below, derive an equation for the factor of safety against sliding using the plane failure equilibrium technique. The slope face is vertical with a height H , the failure plane is oriented at an angle ψ , and a vertical load, L , is applied to the upper slope. The unit weight of the rock is γ . The equation derived must be a function of $H, L, c, \phi, \psi, \gamma$.

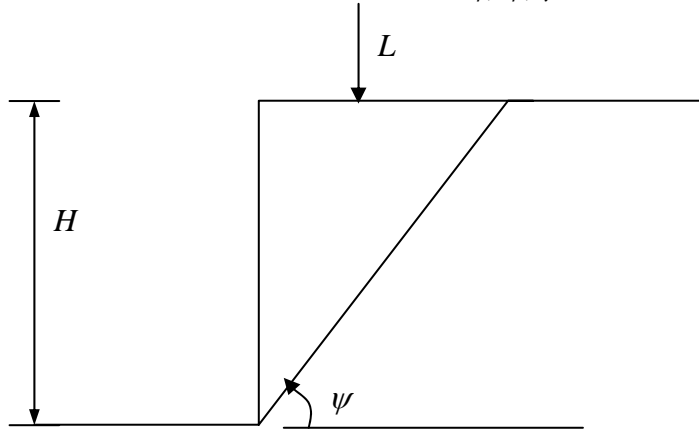

SOLUTION:

$$\text{Wedge Weight} = W = V\gamma$$

Assuming depth is 1 unit length:

$$\Rightarrow V = \frac{1}{2}BH(1)$$

$$A = \frac{H}{\sin \psi} \quad B = \frac{H}{\tan \psi}$$

$$V = \left(\frac{1}{2}\right)\left(\frac{H}{\tan \psi}\right)(H) = \frac{H^2}{2 \tan \psi}$$

$$W = V\gamma = \frac{H^2\gamma}{2 \tan \psi}$$

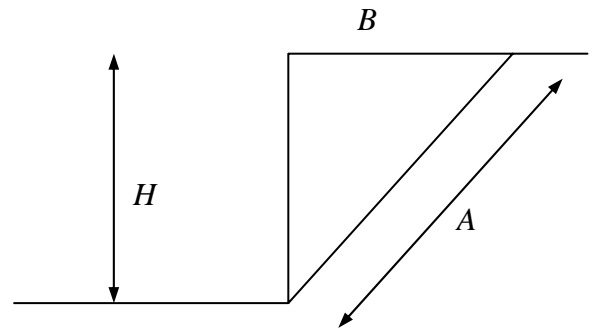

$$\text{Factor of Safety} = \frac{\text{resisting Forces}}{\text{driving Forces}} = \frac{cA + (W + L) \cos \theta \tan \phi}{(W + L) \sin \theta}$$

$$FS = \frac{c \left(\frac{H}{\sin \psi} \right) + \left(\frac{H^2 \gamma}{2 \tan \psi} + L \right) \cos \psi \tan \phi}{\left(\frac{H^2 \gamma}{2 \tan \psi} + L \right) \sin \psi}$$

b) Using the equation derived in Question 2a, determine the factor of safety against failure of a slope with the following properties:

$$H=15\text{m}, \psi=50^\circ, \gamma=2.7 \text{ tonnes/m}^3, c=5 \text{ tonnes/m}^2, \phi=35^\circ, \text{ and } L=20 \text{ tonnes}$$

SOLUTION:

$$\begin{aligned}
 FS &= \frac{c \left(\frac{H}{\sin \psi} \right) + \left(\frac{H^2 \gamma}{2 \tan \psi} + L \right) \cos \psi \tan \phi}{\left(\frac{H^2 \gamma}{2 \tan \psi} + L \right) \sin \psi} \\
 &= \frac{5 \left(\frac{15}{\sin(50)} \right) + \left(\frac{(15)^2 (2.7)}{2 \tan(50)} + 20 \right) \cos(50) \tan(35)}{\left(\frac{(15)^2 (2.7)}{2 \tan(50)} + 20 \right) \sin(50)} \\
 &= \frac{97.906 + 123.718}{210.568} \\
 &\Rightarrow FS = 1.0525
 \end{aligned}$$

Confirm Results with RocPlane:

Deterministic Input Data ? ▲ ✕

Geometry | Strength | Forces

Slope

Angle (deg): 90 

Height (m): 15 

Unit Weight (t/m3): 2.7

Failure Plane

Angle (deg): 50 

Waviness (deg): 0

* Waviness = [Avg. Angle] - [Min. Angle]

Tension Crack

Angle (deg): 90 

Minimum FS Location 

Specify Location

Distance from Crest (m): 0

Upper Face

Angle (deg): 0 

Bench Analysis

Width (m): 12.5865

Safety Factor = 1.0525
 Wedge Weight = 254.877 tonnes/m
 Normal Force = 176.687 tonnes/m
 Resisting = 221.623 tonnes/m
 Driving = 210.568 tonnes/m

Distance in meters
 Force in Tonnes (1000 kg)

OK Cancel Apply

Geometry input data for slope in 2b

Deterministic Input Data ? ▲ ✕

Geometry | Strength | Forces

Shear Strength Model:

Mohr-Coulomb $\tau = c + \sigma_n \tan \phi$

Friction Angle (deg): 35

Cohesion (t/m2): 5

Safety Factor = 1.0525
 Wedge Weight = 254.877 tonnes/m
 Normal Force = 176.687 tonnes/m
 Resisting = 221.623 tonnes/m
 Driving = 210.568 tonnes/m

Distance in meters
 Force in Tonnes (1000 kg)

OK Cancel Apply

Strength input data for slope in 2b

Deterministic Input Data

Geometry | Strength | Forces

Water Pressure

Unit Weight (t/m³): 1

Pressure Distribution Model:
Peak Pressure - Mid Height

Percent Filled (%): 100

Seismic

Seismic Coefficient: 0

Direction:
Horizontal

External Forces

Number of Forces: 1

#	Angle*	Force (t/m)
1	90	20

Safety Factor = 1.0525
Wedge Weight = 254.977 tonnes/m
Normal Force = 176.687 tonnes/m
Resisting = 221.623 tonnes/m
Driving = 210.568 tonnes/m

OK Cancel Apply

Force input data for slope in 2b

c) Calculate the value of L that will cause a failure in the slope described in Question 2b.

SOLUTION:

The slope will fail when $FS=1$. Using the equations developed in Question 2a, setting FS to 1, substituting the values given in Question 2b and rearranging to isolate L :

$$1 = \frac{c \left(\frac{H}{\sin \psi} \right) + \left(\frac{H^2 \gamma}{2 \tan \psi} + L \right) \cos \psi \tan \phi}{\left(\frac{H^2 \gamma}{2 \tan \psi} + L \right) \sin \psi}$$

$$L = \frac{\frac{cH}{\sin \psi} + \frac{H^2 \gamma \cos \psi \tan \phi}{2 \tan \psi} - \frac{H^2 \gamma \sin \psi}{2 \tan \psi}}{\sin \psi - \cos \psi \tan \phi}$$

$$L = \frac{\frac{(5)(15)}{\sin(50)} + \frac{(15)^2 (2.7) \cos(50) \tan(35)}{2 \tan(50)} - \frac{(15)^2 (2.7) \sin(50)}{2 \tan(50)}}{\sin(50) - \cos(50) \tan(35)}$$

$$\Rightarrow L = 55 \text{ tonnes}$$

d) Assuming a water table exists along the ground surface, use *RocPlane* to calculate the FS of the slope described in 2b. Use a triangular water pressure distribution and 1 t/m as the unit weight of water.

SOLUTION:

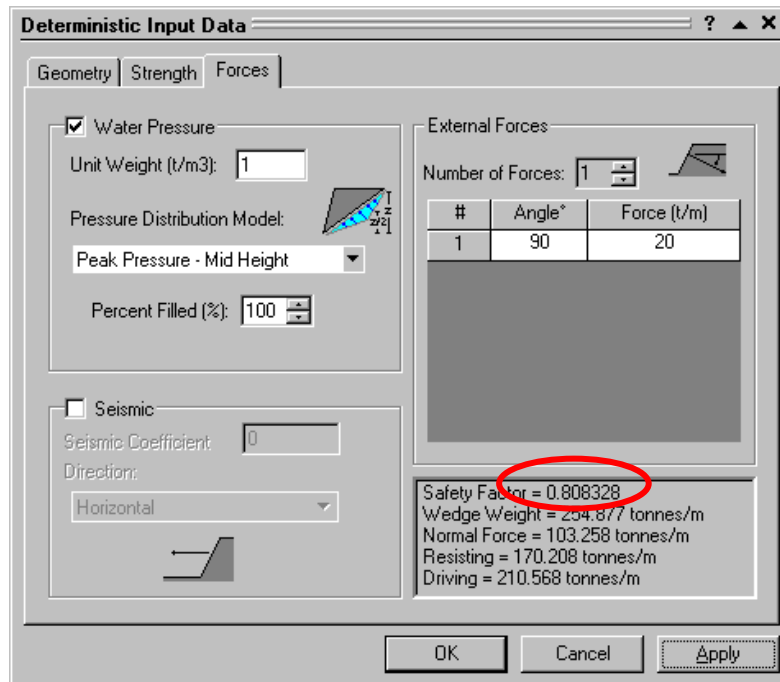

Force input for the slope in 2d

When the given values are input into *RocPlane*, the resulting factor of safety is 0.808328.

e) Using *RocPlane*, plot the distribution of factor of safety versus the level of water in the joint plane. At what level does the slope fail?

SOLUTION:

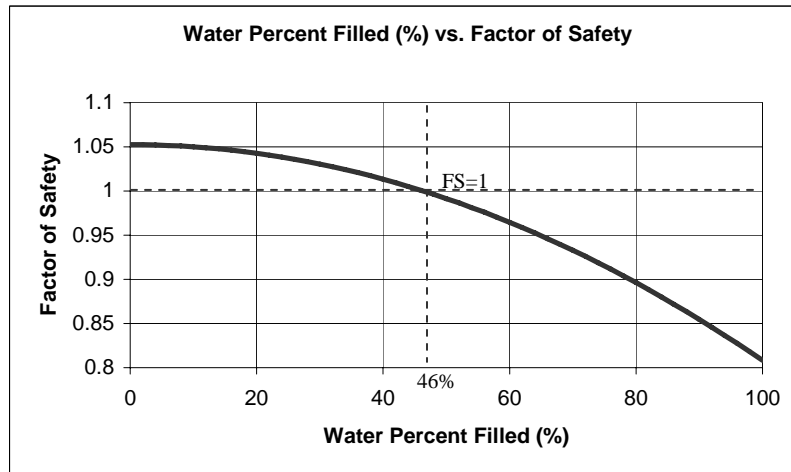

As shown on the sensitivity analysis plot created by *RocPlane* (or reading values from the spreadsheet generated), the slope will fail when the level of water exceeds 46% of the height of the joint plane. (i.e. when the FS is less than 1)

f) Piezometers placed in the slope measured a mean water elevation of 4.5m above the toe of the slope. Assuming an exponential distribution of the water levels across the full height of the slope, determine the probability of slope failure. If drainage from the toe of the slope is prevented, how does this affect the results?

SOLUTION:

$$\text{Mean Value(\%)} = \frac{4.5}{15} (100) = 30\%$$

To obtain a range of values over the entire height of the slope, the relative minimum and relative maximum values must be used. The absolute minimum occurs during dry conditions and the absolute maximum occurs when the water level is the same as the total height of the slope.

To convert these conditions to relative measurements:

$$\begin{aligned} \text{absolute maximum} &= \text{mean value} + \text{relative maximum} \\ 100 &= 30 + \text{relative max} \\ \text{relative max} &= 70\% \end{aligned}$$

$$\begin{aligned} \text{absolute minimum} &= \text{mean value} - \text{relative minimum} \\ 0 &= 30 - \text{relative minimum} \\ \text{relative minimum} &= 30\% \end{aligned}$$

Probabilistic Input Data

Seismic		Forces		Sampling	
Slope	Upper Face	Failure Plane	Strength	Tension Crack	Water

Water Pressure Exists

Unit Weight (t/m3):

Pressure Distribution Model: 

Peak Pressure - Mid Height

Percent Filled

Mean Value: %

Statistical Distribution: Exponential

Standard Deviation: %

Relative Minimum: %

Relative Maximum: %

OK Cancel Apply

Probabilistic data input for the water force in 2f

When these values are input into *RocPlane*, with the relative minimum set to 30% and the relative maximum set to 70%, the probability of failure is 0.159.

If drainage from the toe of the slope is prevented, the probability of failure will increase, as the pressure beneath the slope is not alleviated, and the slope has a greater driving force as more water accumulates and the water level rises.

Probabilistic Input Data

Seismic | Forces | Sampling

Slope | Upper Face | Failure Plane | Strength | Tension Crack | Water

Water Pressure Exists

Unit Weight (t/m3): 1

Pressure Distribution Model: Peak Pressure - Toe

Percent Filled

Mean Value: 30 %

Statistical Distribution: Exponential

Standard Deviation: 0 %

Relative Minimum: 30 %

Relative Maximum: 70 %

OK Cancel Apply

Probabilistic data input for water force when drainage of the slope is prevented

Under these conditions, *RocPlane* calculates the Probability of Failure to be 0.279.

$$\% \text{ difference} = \frac{PF2 - PF1}{PF1} \cdot 100 = \frac{0.279 - 0.159}{0.159} \cdot 100 = 75.5\%$$

If the slope is not drained, the probability of failure increases by 75.5%.

ROCPLANE SAMPLE PROBLEM #3

a) Using the Limit Equilibrium Models as defined in Hoek's *Practical Rock Engineering* [1], calculate the minimum and maximum possible factors of safety for the entire Sau Mau Ping slope under fully saturated conditions and earthquake loading. The cohesive strength of the surface was determined to range from 0.05MPa to 0.2MPa, and the friction angle from 30 to 45 degrees.

Additional Information:

$$H = 60m \quad \psi_f = 50^\circ \quad \psi_p = 35^\circ \quad \alpha = 0.08g \quad \gamma_r = 0.027MN/m^3 \quad \gamma_w = 0.01MN/m^3$$

SOLUTION:

Using the equations defined on pg. 96 of Hoek's notes [1]:

$$A = \frac{H}{\sin \psi_p} = \frac{60}{\sin(35)} = 104.6m^2$$

$$W = \frac{\gamma_r H^2}{2} (\cot \psi_p - \cot \psi_f) = \frac{(0.027)(60)^2}{2} (\cot(35) - \cot(50)) = 28.63MN/m$$

Since the slope is fully saturated, the height of the water is equal to the height of the slope.

$$U = \frac{\gamma_w H_w^2}{4 \sin \psi_p} = \frac{(0.01)(60)^2}{4 \sin(35)} = 15.69MN/m$$

$$FS = \frac{104.6c + [28.63(\cos(35) - 0.08 \sin(35)) - 15.69 + 0] \tan \phi}{28.63(\sin(35) + 0.08 \cos(35)) - 0} = \frac{104.6c + 6.45 \tan \phi}{18.30}$$

$$FS = 5.72c + 0.35 \tan \phi$$

Note that the value of T is equal to zero as there is no anchor system present.

When $c = 0.05$ and $\phi = 30$:

$$\Rightarrow FS = 5.72(0.05) + 0.35 \tan(30) = 0.286 + 0.202 = 0.49$$

When $c = 0.2$ and $\phi = 45$:

$$\Rightarrow FS = 5.72(0.2) + 0.35 \tan(45) = 1.144 + 0.35 = 1.49$$

b) Under the same conditions as described in Question 3a, recalculate the maximum and minimum factors of safety of the Sau Mau Ping slope assuming a water filled tension crack is present. What conclusions can be made about the effect of a tension crack on the forces acting on the slope?

SOLUTION:

Using the equations defined on pg. 97 of Hoek's notes [1],

$$z_w = H \left(1 - \sqrt{\cot \psi_f \tan \psi_p} \right) = 60 \left(1 - \sqrt{\cot(50) \tan(35)} \right) = 14.0m$$

$$A = \frac{H - z_w}{\sin \psi_p} = \frac{60 - 14.0}{\sin(35)} = 80.2m^2 / m$$

$$W = \frac{\gamma_r H^2}{2} \left(\left(1 - \left(\frac{z_w}{H} \right)^2 \right) \cot \psi_p - \cot \psi_f \right) = \frac{(0.027)(60)^2}{2} \left[\left(1 - \left(\frac{14}{60} \right)^2 \right) \cot(35) - \cot(50) \right] = 24.85MN / m$$

$$U = \frac{\gamma_w z_w A}{2} = \frac{(0.01)(14)(80.2)}{2} = 5.61MN / m$$

$$V = \frac{\gamma_w z_w^2}{2} = \frac{(0.01)(14)^2}{2} = 0.98MN / m$$

$$FS = \frac{80.2c + (24.85(\cos(35) - 0.08 \sin(35)) - 5.61 - 0.98 \sin(35) + 0) \tan \phi}{24.85(\sin(35) + 0.08 \cos(35)) + 0.98 \cos(35) - 0} = \frac{80.2c + 13.04 \tan \phi}{16.685}$$

$$FS = 4.807c + 0.782 \tan \phi$$

When $c = 0.05MPa$ and $\phi = 30^\circ$

$$\Rightarrow FS = 0.24 + 0.45 = 0.69$$

When $c = 0.2MPa$ and $\phi = 45^\circ$

$$\Rightarrow FS = 0.96 + 0.782 = 1.74$$

CONCLUSIONS: It can be seen that when a tension crack is present, the contribution of cohesion decreases and that of friction increases as compared to when there is no tension crack.

c) In the case of the Sau Mau Ping slope, it was impossible to determine whether or not a tension crack existed. Assuming this was not the case and using the data given in Hoek's notes [1], how far from the crest of the slope would you expect to find the tension crack?

SOLUTION:

Data Given:

$$\psi_f = 50^\circ$$

$$\psi_p = 35^\circ$$

$$H = 60m$$

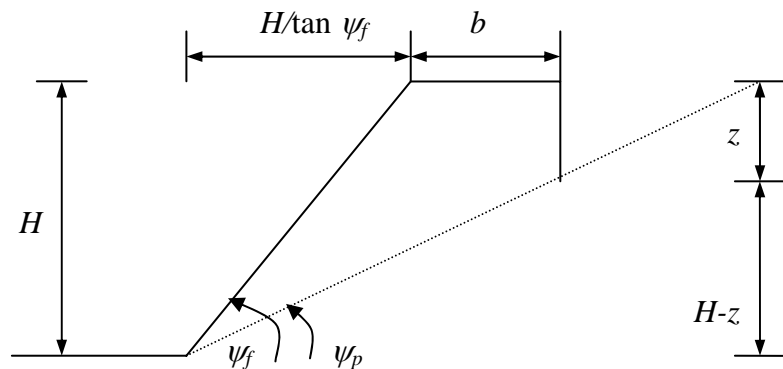

$$b = \frac{H - z}{\tan \psi_p} - \frac{H}{\tan \psi_f}$$

From pg 97 of Hoek's notes [1] and Hoek and Bray(1974), the critical crack depth is :

$$z = H \left(1 - \sqrt{\cot \psi_f \tan \psi_p} \right)$$

$$b = \frac{H - H \left(1 - \sqrt{\cot \psi_f \tan \psi_p} \right)}{\tan \psi_p} - \frac{H}{\tan \psi_f} = H \left[\frac{\sqrt{\cot \psi_f \tan \psi_p}}{\tan \psi_p} - \frac{1}{\tan \psi_f} \right]$$

$$\Rightarrow b = H \left[\sqrt{\cot \psi_f \cot \psi_p} - \cot \psi_f \right]$$

Substituting the given values:

$$b = 60 \left(\sqrt{\cot(50) \cot(35)} - \cot(50) \right)$$

$$\Rightarrow b = 15.3m$$

Therefore, the tension crack would lay 15.3m from the crest of the slope.

d) For the Sau Mau Ping slope, assuming the slope is fully saturated and subjected to earthquake loading, determine the optimum cable orientation θ , and tension T , for a factor of safety of 1.5. Analyze both situations (tension crack absent, present) by using the information given in the previous questions, but assuming a friction angle of 35 degrees.

SOLUTION:

CASE I: No tension crack

The calculations in Question 3a gave that $A=104.6 \text{ m}^2/\text{m}$, $W=28.63\text{MN}/\text{m}$, and $U=15.69\text{MN}/\text{m}$.

$$\Rightarrow FS = \frac{104.6c + (6.45 + T \cos \theta) \tan \phi}{18.3 - T \sin \theta}$$

After rearranging to solve for T :

$$T = \frac{18.3F - 104.6c - 6.45 \tan \phi}{FS \sin \theta + \tan \phi \cos \theta}$$

To determine the optimum cable orientation, an expression is derived by finding the partial derivative of T with respect to θ and then equating this to zero.

$$\frac{\partial T}{\partial \theta} = \frac{-(18.3FS - 104.6c - 6.45 \tan \phi)(FS \cos \theta - \tan \phi \sin \theta)}{(FS \sin \theta + \tan \phi \cos \theta)^2} = 0$$

$$\Rightarrow FS \cos \theta - \tan \phi \sin \theta = 0 \Rightarrow \tan \theta = \frac{FS}{\tan \phi}$$

$$\text{or } 18.3FS - 104.6c - 6.45 \tan \phi = 0 \Rightarrow \text{not acceptable}$$

$$\therefore \text{when } FS = 1.5, \phi = 35^\circ$$

$$\tan \theta = \frac{1.5}{\tan(35)}$$

$$\Rightarrow \theta = 65^\circ$$

CASE II: Tension crack present

The calculations in Question 3b gave that $z=14.0\text{m}$, $A=80.2\text{m}^2/\text{m}$, $W=24.85\text{MN}/\text{m}$, $U=5.61\text{MN}/\text{m}$ and $V=0.98\text{MN}/\text{m}$.

$$\Rightarrow FS = \frac{80.2c + (13.04 + T \cos \theta) \tan \phi}{16.685 - T \sin \theta}$$

Which after rearrangement, leads to the following expression:

$$T = \frac{16.685 - 80.2c - 13.04 \tan \phi}{FS \sin \theta + \tan \phi \cos \theta}$$

$$\Rightarrow \tan \theta = \frac{FS}{\tan \phi}$$

Or, the same result as that which was obtained in the first case.

\therefore when $FS = 1.5$, $\phi = 35^\circ$

$$\tan \theta = \frac{1.5}{\tan(35)}$$

$$\Rightarrow \theta = 65^\circ$$

ROCPLANE SAMPLE PROBLEM #4

A bridge abutment, which is fully drained and located in an area of negligible seismic risk, is found to have a through-going plane dipping parallel to the slope face and daylighting in the toe of the slope. A bridge pier runs parallel to the slope crest, as illustrated in the figure below, and applies a load of 60 MN/m through the centre of gravity of the wedge. The slope height $H = 40$ m, the slope face angle $\psi_f = 60^\circ$ and the angle of the potential failure surface $\psi_p = 30^\circ$. The unit weight of the rock mass is $\gamma_r = 0.026$ MN/m³ and the failure surface, which shows evidence of previous shearing, has zero cohesion and a friction angle of $\phi = 25^\circ$.

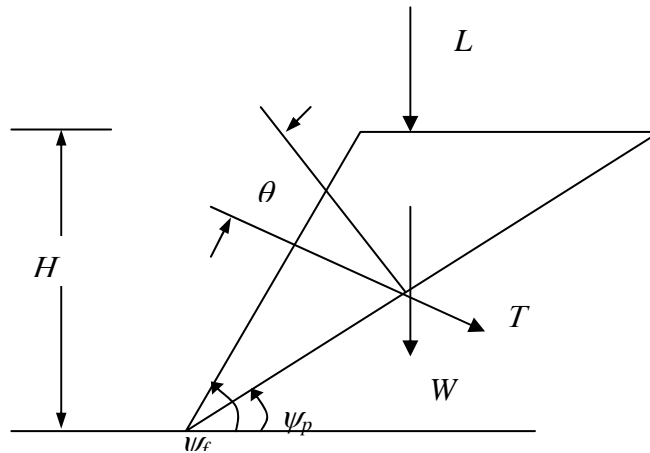

Calculate the bolt force T required to provide a factor of safety of 1.2, assuming that the bolts are installed normal to the slope face as shown in the figure above.

SOLUTION:

Given that:

$$L = 60 \text{ MN} / \text{m}$$

$$H = 40 \text{ m}$$

$$\psi_f = 60^\circ$$

$$\psi_p = 30^\circ$$

$$\gamma_r = 0.026 \text{ MN} / \text{m}^3$$

$$c = 0$$

$$\phi = 25^\circ$$

Find T such that $FS=1.2$

$$W = \frac{\gamma_r H^2 (\cot \psi_p - \cot \psi_f)}{2} = \frac{(0.026)(40)^2}{2} (\cot(30) - \cot(60)) = \frac{0.026(1600)}{2} (1.732 - .57735)$$

$$\Rightarrow W = 24.01672MN / m$$

$$FS = 1.2 = \frac{((W + L)\cos \psi_p + T \cos \theta)\tan \phi}{(W + L)\sin \psi_p - T \sin \theta} = \frac{((24 + 60)\cos(30) + T \cos \theta)\tan(25)}{(24 + 60)\sin(30) - T \sin \theta}$$

$$50.4 - 1.2T \sin \theta = 33.92881 + 0.466307T \cos \theta$$

$$\Rightarrow T = \frac{16.48119}{0.466307 \cos \theta + 1.2 \sin \theta}$$

Since the bolts should be oriented to minimize T :

$$\frac{\partial T}{\partial \theta} = \frac{-16.48119(-0.466307 \sin \theta + 1.2 \cos \theta)}{(0.466307 \cos \theta + 1.2 \sin \theta)^2} = 0$$

$$-0.466307 \sin \theta + 1.2 \cos \theta = 0$$

$$1.2 \cos \theta = 0.466307 \sin \theta$$

$$\tan \theta = 2.573409$$

$$\Rightarrow \theta = 68.76^\circ$$

$$T = \frac{16.48119}{0.466307 \cos(68.76) + 1.2 \sin(68.76)} = \frac{16.48119}{0.466307(0.362275) + 1.2(0.932071)} = \frac{16.48119}{1.3537846}$$

$$\Rightarrow T = 12.174159MN / m$$

ROCPLANE SAMPLE PROBLEM #5

a)

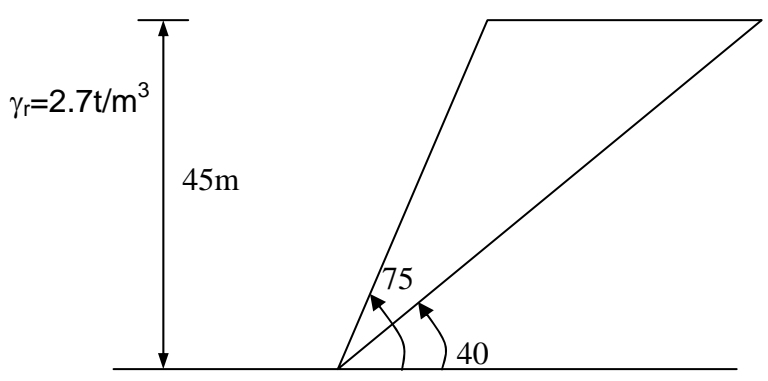

The dry rock slope pictured above has the following Barton-Bandis strength parameters:

$JRC = 6$
 $JCS = 11500t/m^2$
 $\phi_b = 25^\circ$

Using *RocPlane*, determine the factor of safety. Assume a tension crack may or may not exist.

SOLUTION:

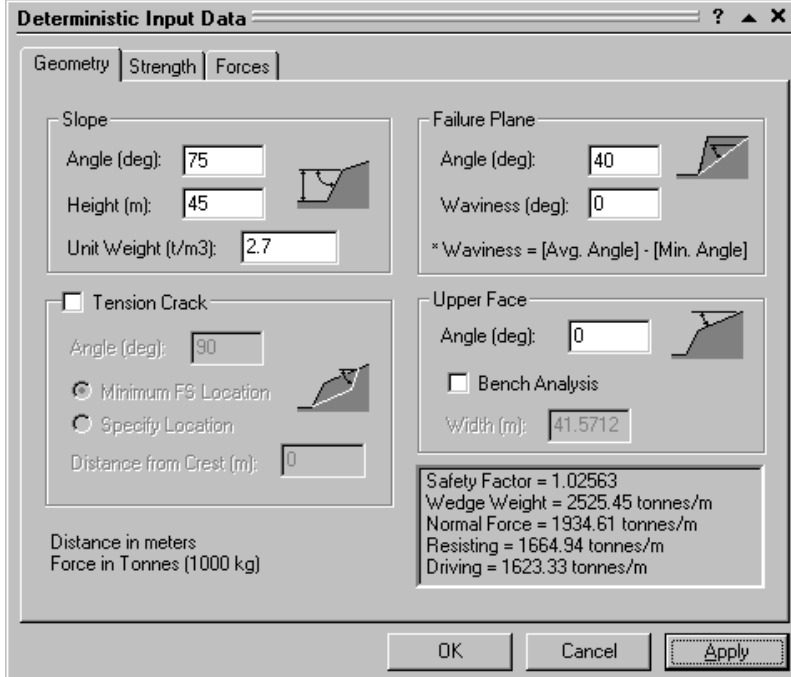

Deterministic Input Data

Geometry | Strength | Forces

Slope

Angle (deg): 75

Height (m): 45

Unit Weight (t/m3): 2.7

Tension Crack

Angle (deg): 90

Minimum FS Location

Specify Location

Distance from Crest (m): 0

Failure Plane

Angle (deg): 40

Waviness (deg): 0

* Waviness = [Avg. Angle] - [Min. Angle]

Upper Face

Angle (deg): 0

Bench Analysis

Width (m): 41.5712

Safety Factor = 1.02563
 Wedge Weight = 2525.45 tonnes/m
 Normal Force = 1934.61 tonnes/m
 Resisting = 1664.94 tonnes/m
 Driving = 1623.33 tonnes/m

Distance in meters
 Force in Tonnes (1000 kg)

OK Cancel Apply

Geometry input data for slope with no tension crack

Deterministic Input Data

Geometry | Strength | Forces

Shear Strength Model:
 Barton-Bandis $\tau = \sigma_n \tan \left[JRC \log_{10} \left(\frac{JCS}{\sigma_n} \right) + \phi_b \right]$

JRC: JCS (t/m2): Phib (deg):

Distance in meters
 Force in Tonnes (1000 kg)

Safety Factor = 1.02563
 Wedge Weight = 2525.45 tonnes/m
 Normal Force = 1334.61 tonnes/m
 Resisting = 1664.94 tonnes/m
 Driving = 1623.33 tonnes/m

OK Cancel Apply

Strength input data for slope with no tension crack

Using *RocPlane*, the Factor of Safety was determined to be 1.02563 when there was no tension crack.



Deterministic Input Data

Geometry | Strength | Forces

Slope

Angle (deg): 
 Height (m):
 Unit Weight (t/m3):

Tension Crack

Angle (deg): 
 Minimum FS Location 
 Specify Location
 Distance from Crest (m):

Failure Plane

Angle (deg): 
 Waviness (deg):
 * Waviness = [Avg. Angle] - [Min. Angle]

Upper Face

Angle (deg): 
 Bench Analysis
 Width (m):

Distance in meters
 Force in Tonnes (1000 kg)

Safety Factor = 0.997189
 Wedge Weight = 1624.63 tonnes/m
 Normal Force = 1244.54 tonnes/m
 Resisting = 1041.36 tonnes/m
 Driving = 1044.29 tonnes/m

OK Cancel Apply

Geometry input data for slope with a tension crack

Using *RocPlane*, the Factor of Safety was determined to be 0.997189 when there was a tension crack.

b) Where would you expect a tension crack to exist? How deep would it be?

SOLUTION:

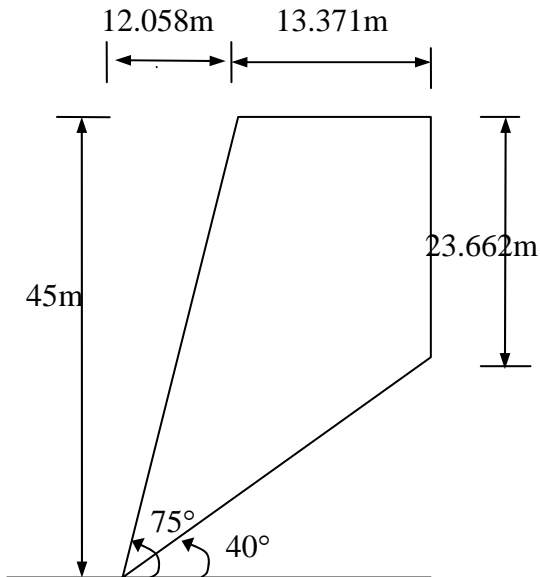

Using the 2D view of the slope in *RocPlane*, it is seen that if a tension crack existed, it would be located 13.371m away from the slope crest with a depth of 23.662m.

c) If the overall slope length is 100m (as shown below), how many grouted tiebacks would be required to stabilize the slope to a design FS=1.25. Assume the tiebacks are pre-tensioned (active) bolts with a capacity of 25 tonnes and will be installed horizontally. What is the optimal installation angle?

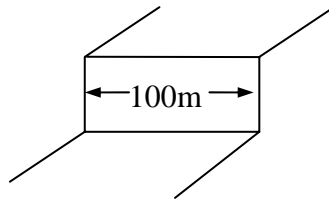

SOLUTION:

No Tension Crack:

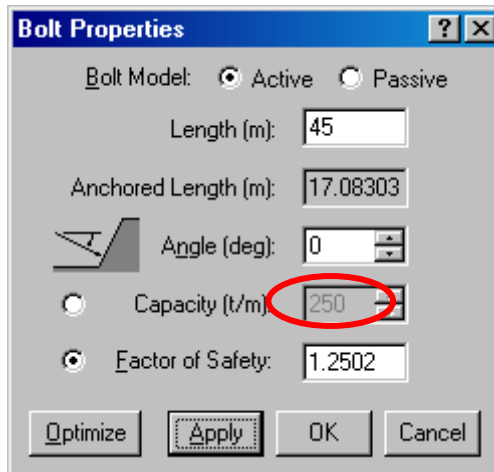

Bolt input data for slope with a tension crack

The capacity required by the tiebacks is calculated to be 250t/m.

$$\text{capacity required} = 250t / m$$

$$\text{total length of slope} = 100m$$

$$\text{required Support} = 250 \frac{t}{m} \cdot 100m = 25000t$$

$$\text{bolt capacity} = 25t / \text{bolt}$$

$$\text{number of bolts required} = \frac{25000t}{25t / \text{bolt}}$$

⇒ 1000 bolts are required to achieve FS = 1.25

Tension Crack Present:

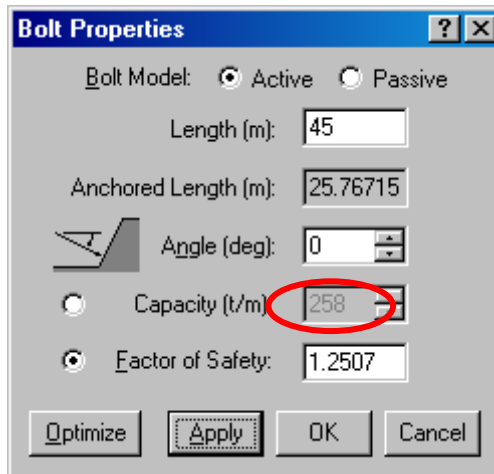

Bolt input data for slope with a tension crack

The capacity required by the tiebacks is calculated to be 258t/m.

$$\text{required Support} = 258 \frac{t}{m} \bullet 100m = 25800t$$

$$\text{number of bolts required} = \frac{25800t}{25t / \text{bolt}}$$

⇒ 1032 bolts are required to achieve FS = 1.25

To find the optimal installation angle of both cases, the given bolt properties were optimized. To do this, the Optimize button in the Bolt Properties dialogue was selected.

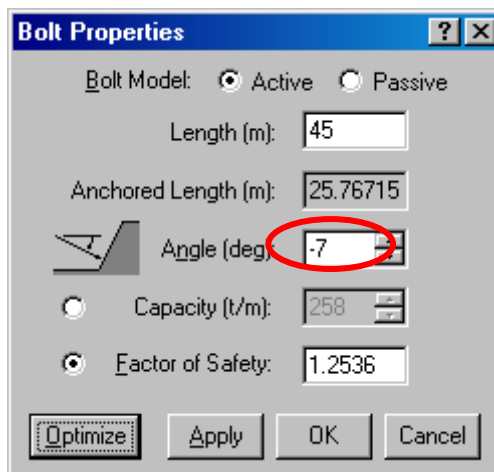

Bolt input data for both slopes after optimizing the installation angle

⇒ The result was an installation angle of -7° from the horizontal.

ROCPLANE SAMPLE PROBLEM #6

The following slope of unit weight 2.5 t/m^3 is undergoing planar failure. The slope has a 15m deep tension crack situated 8.660m away from its crest. There are no seismic forces present, but the water table has filled the tension crack to a height of 25% . Using *RocPlane*, determine the factor of safety of this slope and conduct a sensitivity analysis on cohesion, friction angle, failure plane angle, and percent tension crack filled.

The unit weight of water is 0.981 t/m^3

Parameter	Mean	Range
Cohesion	2	0-4
Friction Angle	30	28-36
Failure Plane Angle	30	28-36
Percent Tension Crack Filled	25%	0-100%

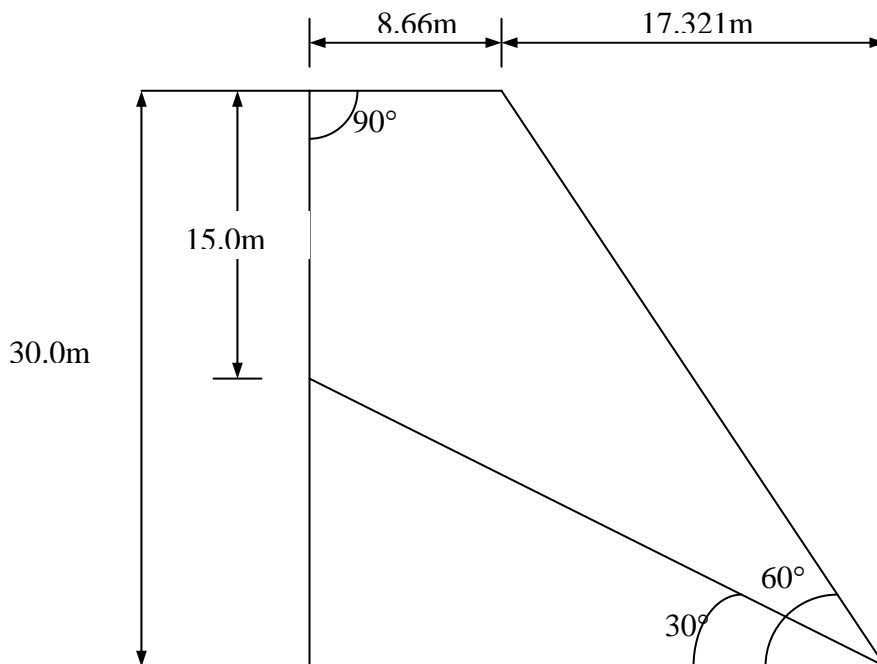

SOLUTION:

Deterministic Input Data

Geometry | Strength | Forces

Slope

Angle (deg): 60
Height (m): 30
Unit Weight (t/m³): 2.5

Failure Plane

Angle (deg): 30
Waviness (deg): 0
*Waviness = [Avg. Angle] · [Min. Angle]

Tension Crack

Angle (deg): 90
 Minimum FS Location
 Specify Location
Distance from Crest (m): 8.66

Upper Face

Angle (deg): 0
 Bench Analysis
Width (m): 34.641

Safety Factor = 1.04898
Wedge Weight = 811.889 tonnes/m
Normal Force = 644.487 tonnes/m
Resisting = 432.094 tonnes/m
Driving = 411.918 tonnes/m

Distance in meters
Force in Tonnes (1000 kg)

OK Cancel Apply

Geometry Data Input

Deterministic Input Data

Geometry | Strength | Forces

Shear Strength Model:
Mohr-Coulomb $\tau = c + \sigma_n \tan \phi$

Friction Angle (deg): 30
Cohesion (t/m²): 2

Safety Factor = 1.04898
Wedge Weight = 811.889 tonnes/m
Normal Force = 644.487 tonnes/m
Resisting = 432.094 tonnes/m
Driving = 411.918 tonnes/m

Distance in meters
Force in Tonnes (1000 kg)

OK Cancel Apply

Strength Data Input

Deterministic Input Data

Geometry | Strength | Forces

Water Pressure

Unit Weight (t/m³): 0.981

Pressure Distribution Model: Peak Pressure - TC Base

Percent Filled TC (%): 25

No Failure Plane Pressure

Seismic

Seismic Coefficient: 0.08

Direction: Horizontal

External Forces

Number of Forces: 0

#	Angle°	Force (t/m)

Safety Factor = 1.04898
Wedge Weight = 811.889 tonnes/m
Normal Force = 644.487 tonnes/m
Resisting = 432.094 tonnes/m
Driving = 411.918 tonnes/m

OK Cancel Apply

Force Data Input

RocPlane calculated the Factor of Safety to be 1.04898.

Sensitivity Input

Friction Angle From: 28 To: 36 Mean: 30

Failure Plane Angle From: 28 To: 36 Mean: 30

Cohesion From: 0 To: 4 Mean: 2

Water Percent Filled T From: 0 To: 100 Mean: 25

From: 0 To: 0 Mean:

From: 0 To: 0 Mean:

From: 0 To: 0 Mean:

From: 0 To: 0 Mean:

OK Cancel

Sensitivity Analysis Parameters

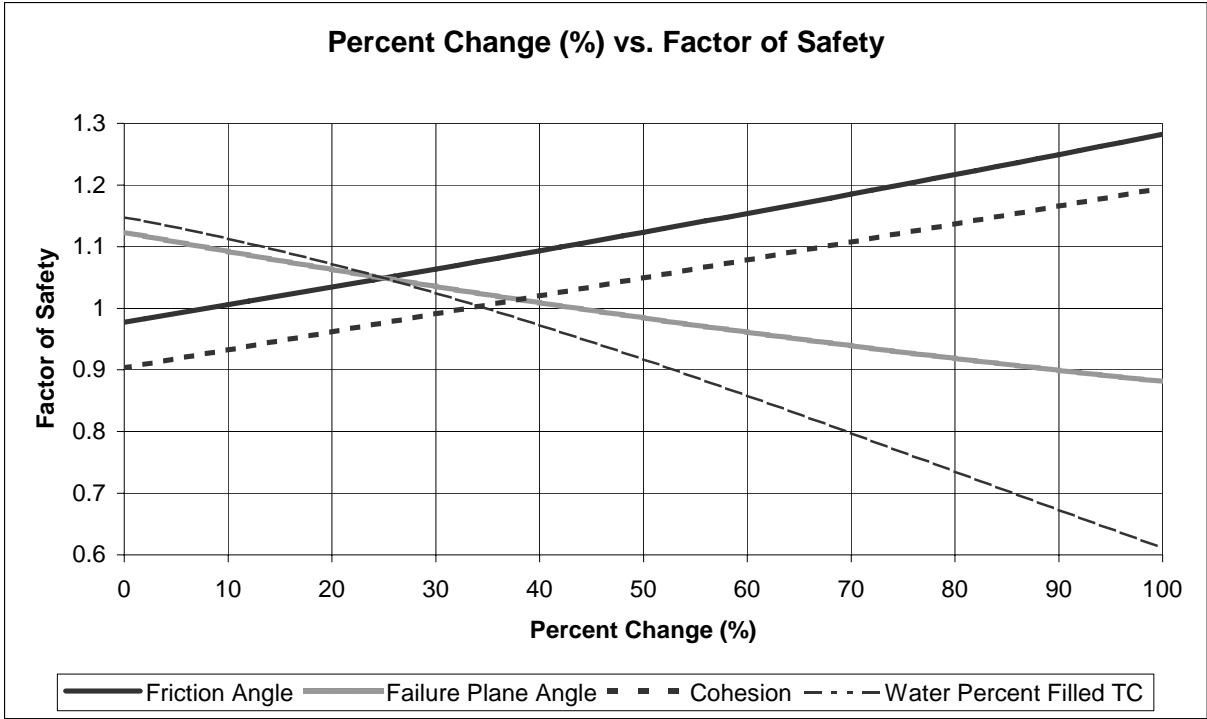

Sensitivity Analysis: Excel Graph Generated from *RocPlane* Data

ROCPLANE SAMPLE PROBLEM #7

a) The slope depicted below has a tension crack that is 51% filled with water and has water leaking out of the failure plane at the slope interface. There is an external force of magnitude 37 t/m acting perpendicular to the upper face. Using *RocPlane*, calculate the Factor of Safety for this plane. The cohesive strength of the slope is 7 t/m², and the angle of friction is 30°.

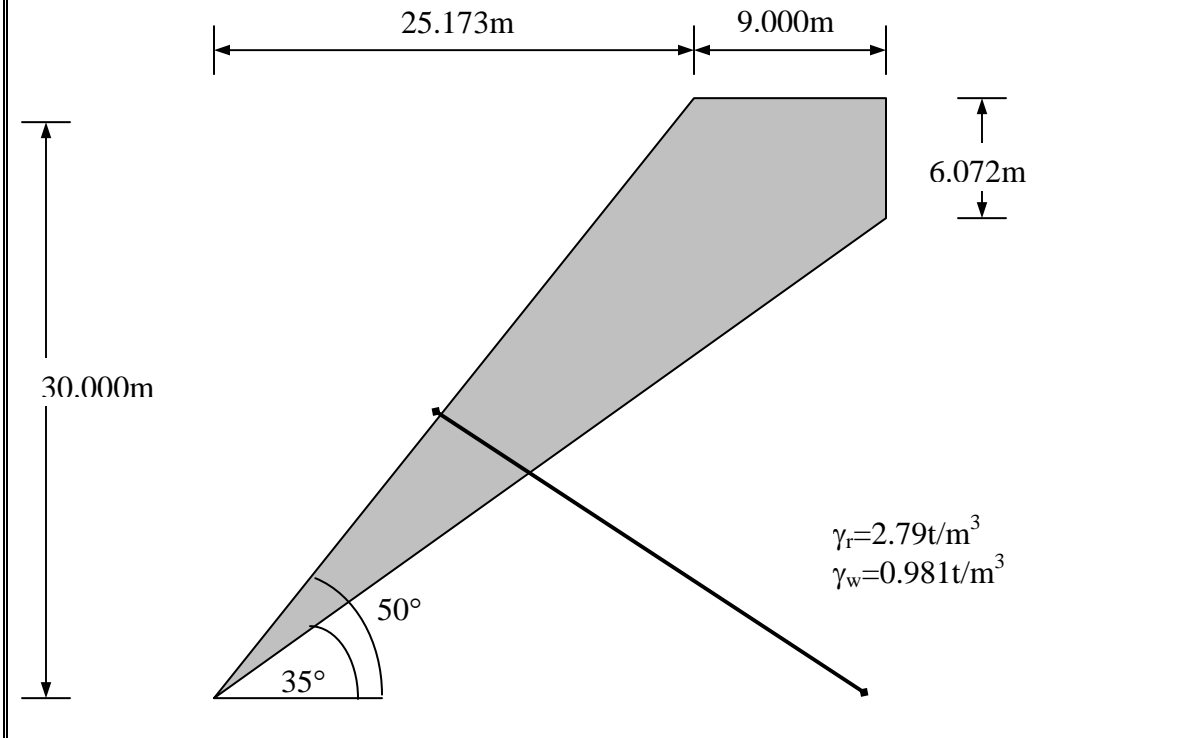

SOLUTION:

Since water is leaking out of the failure plane at the slope interface, we set the water force to have peak pressure at the base of the tension crack.

From *RocPlane*, the calculated Factor of Safety of the slope when it is not reinforced is 1.222.

b) What capacity of (active) rock bolt is required to stabilize the slope to a factor of safety of 1.5 if the bolts are to be installed at an angle of 30°?

SOLUTION:

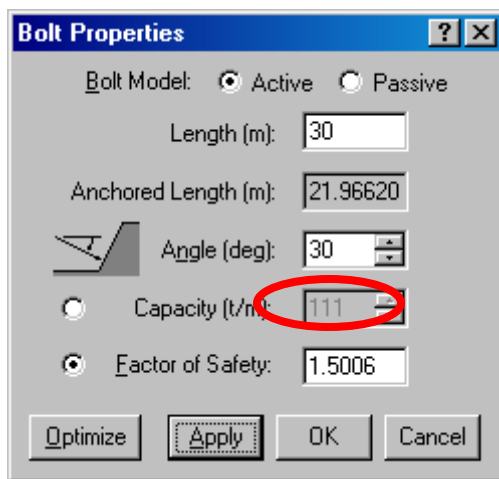

Bolt Properties Input Window

When a bolt is installed at an angle of 30° to achieve a factor of safety of 1.5, the capacity of the bolts required is 111t/m

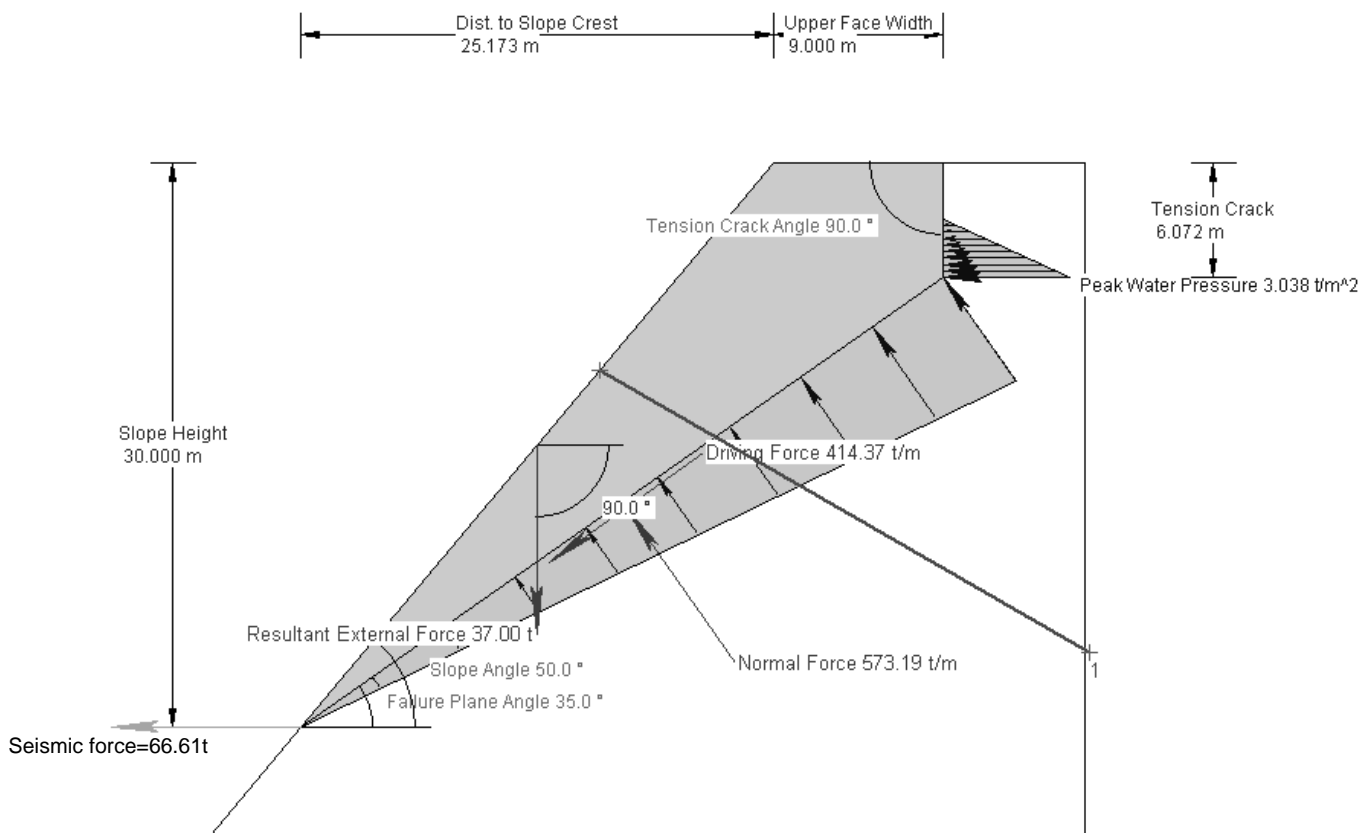

Reinforced Slope

ROCPANE SAMPLE PROBLEM #8

A 5m wide bench in a 100m deep open pit is to be analyzed for stability. The local bench slope is 75 degrees, and there are 10m between benches. Joints dipping at 37 degrees have been identified as being likely to cause planar failure. Through joint mapping, it is found that joint persistence does not exceed 15m. Assume the strength of the joints is $c=1 \text{ t/m}^2$ and $\phi = 30^\circ$.

a) What is the factor of safety of the bench?

SOLUTION:

Using *RocPlane*, the Factor of Safety of the bench is determined to be 1.17521

b) Assuming all benches are equal, what is the overall pit slope angle?
Comment on the overall pit wall stability.

SOLUTION:

OVERALL PIT SLOPE ANGLE:

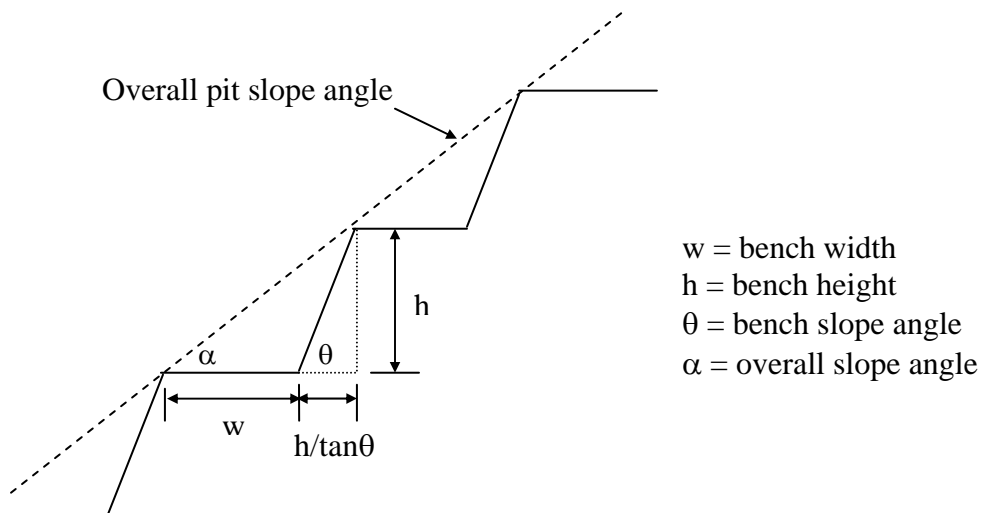

$$\alpha = \tan^{-1} \left(\frac{h}{\left(w + \frac{h}{\tan \theta} \right)} \right) = \tan^{-1} \left(\frac{10}{\left(5 + \frac{10}{\tan 75} \right)} \right) = \tan^{-1}(1.302169)$$

$$\Rightarrow \alpha = 52.5^\circ$$

∴ the overall pit slope angle is 52.5°

Using RocPlane, the factor of safety of the overall wall of height 100m and overall slope angle of 52.5° is 0.80271. This FS is much lower than that of the individual benches.

Since it has been concluded that the persistence is at most 15m, and the slope is 100m, the slope should be stable as the overall slope length is greater than any given joint. However, if a joint persists only for 15m but there is another new joint close to the end of it, tension cracks could be created by stress buildup that could cause the joints to coalesce. The higher the persistence, the fewer joint coalescences need, the lower the factor of safety. In addition, if we consider a joint plane of infinite length, there would be an issue with instability, as the joint plane would exceed the length of the slope.

c) By plotting the factor of safety as a function of bench width, what is the maximum bench width for a design F.S. of 1.1?

SOLUTION:

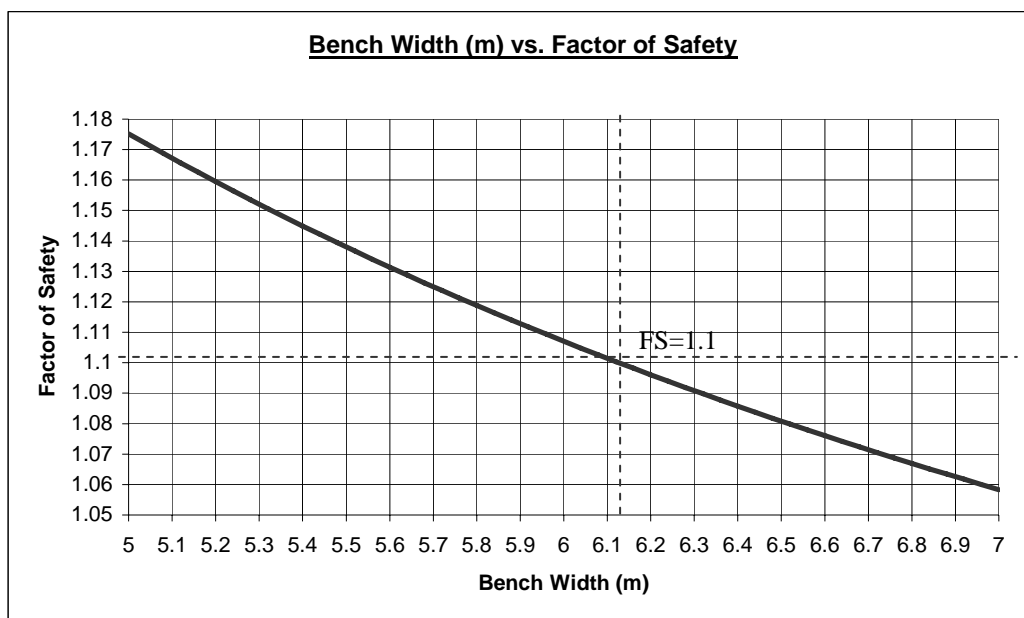

From the graph (or excel data) exported from the Sensitivity Analysis feature of *RocPlane*, it is evident that the maximum bench width for a design factor of safety of 1.1 is 6.12m.

d) If the strength parameters are taken as random variables that are normally distributed, compute the probability of failure of a bench, if the standard deviations of c and ϕ are $0.2t/m^2$ and 2° respectively.

SOLUTION:

To compute the Probability of Failure, we must first set the *RocPlane* program to the Probabilistic mode. Taking the strength parameters as random variables, using the 3 sigma approach for determining the minimum and maximum values, and using the Latin HyperCube sampling method:

$$\sigma_c = 0.2t / m^2$$

$$\sigma_\phi = 2^\circ$$

$$\min_c = 1 - 3\sigma = 1 - 3(0.2) = 0.4$$

$$\max_c = 1 + 3\sigma = 1 + 3(0.2) = 1.6$$

$$\min_\phi = 30 - 3\sigma = 30 - 3(2) = 24$$

$$\max_\phi = 30 + 3\sigma = 30 + 3(2) = 36$$

$$\text{Probability of Failure} = 0.025$$

e) Comment on your choice of sampling method and number of samples.

SOLUTION:

In the sampling menu of the probabilistic input data window, there are two sampling methods from which to choose: Latin HyperCube or Monte Carlo. The Monte Carlo sampling method randomly samples an entire range of values, which in addition to valid numbers, can also result in very small or very large numbers. These extreme values can lead to numerical instability. The Latin HyperCube sampling method gives comparable results to the Monte Carlo method, but uses fewer samples, as it is based on stratified sampling with random selection.

To determine which sampling method yields the most accurate results, the input distribution of both cohesion and the friction angle are plotted by *RocPlane*. They are first plotted using the Monte Carlo sampling method, then the Latin HyperCube method.

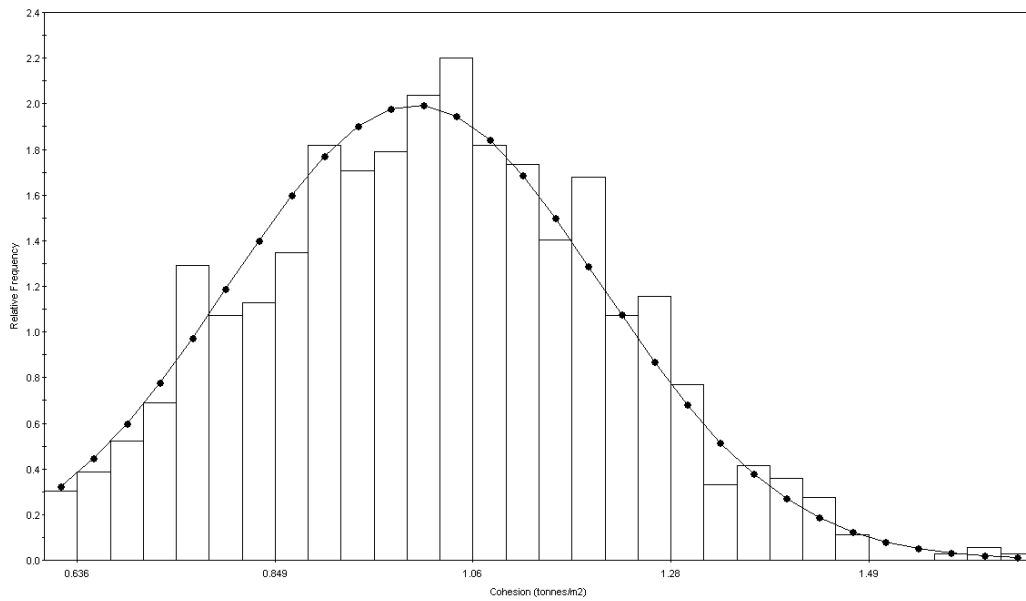

SAMPLED: mean=1.021 s.d.=0.188 min=0.6008 max=1.666 PF=2.5%
 INPUT: NORMAL mean=1 s.d.=0.2 min=0.6 max=2.6

Input Distribution: Cohesion using Monte Carlo Sampling Method

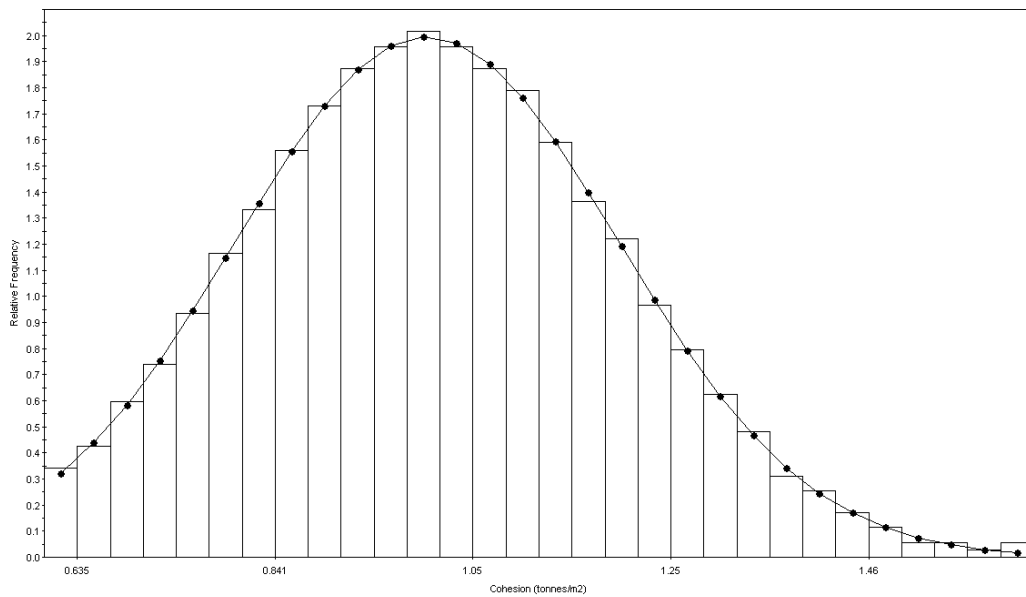

SAMPLED: mean=1.011 s.d.=0.1883 min=0.6005 max=1.633 PF=3.2%
 INPUT: NORMAL mean=1 s.d.=0.2 min=0.6 max=2.6

Input Distribution: Cohesion using Latin Hypercube Sampling Method

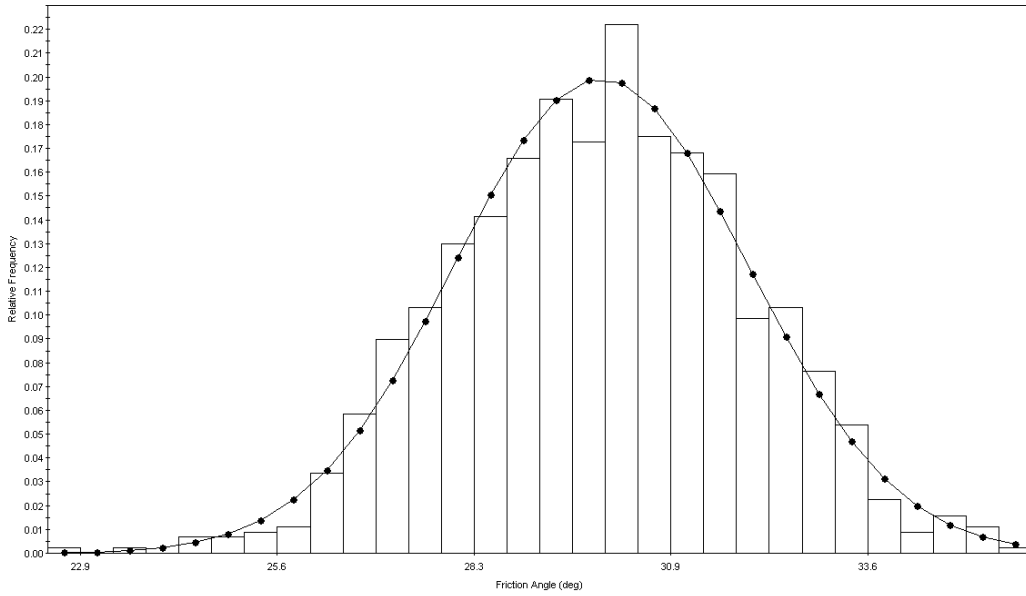

Input Distribution: Friction Angle using Monte Carlo Sampling Method

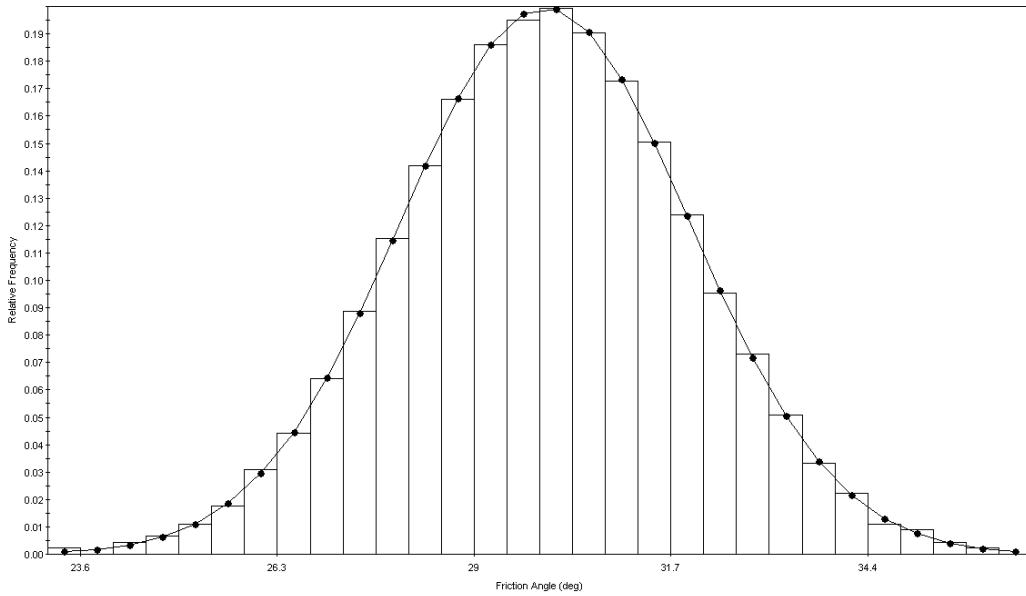

Input Distribution: Friction Angle using Latin HyperCube Sampling Method

From the graphs, it is seen that when samples sizes are relatively small (1000 samples), the Latin HyperCube gives a more accurate distribution than the Monte Carlo method.

If the probability of failure is graphed against the number of samples used in calculation, the following plot results:

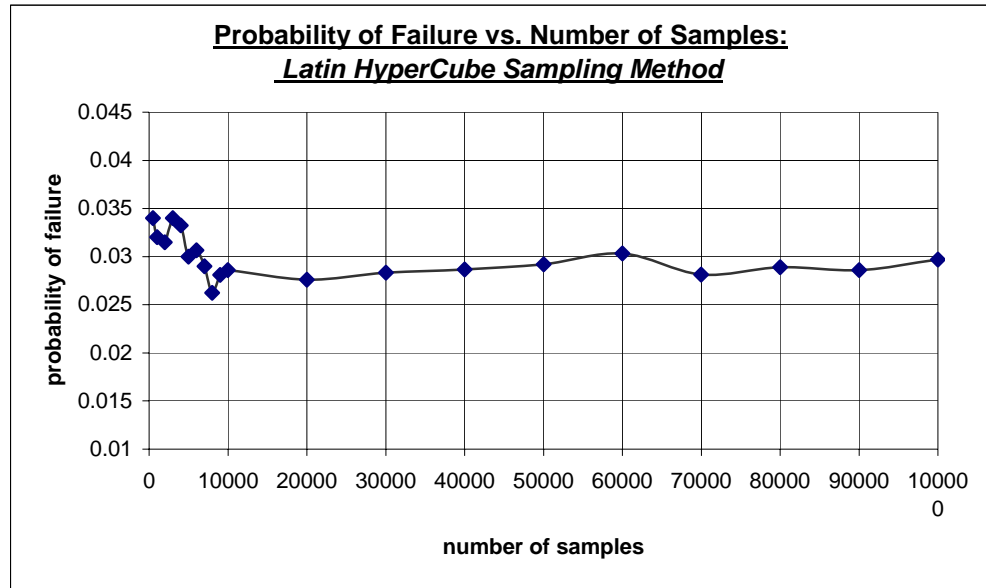

The graph above indicates that as the number of samples increases, the probability of failure converges to a value. If a sample of size of 30000 is used in calculation, the probability of failure is assured to be valid

f) Often, c and ϕ are not independent random variables, but are correlated. Assuming a correlation coefficient of -0.5 , how is the F.S. affected? Plot the sampling of c and ϕ , and verify that it is correct. How does correlation affect the sampling of c and ϕ ?

SOLUTION:

When correlation is applied to the random variables of c and ϕ , the Probability of Failure decreases from 0.025 (when c and ϕ are considered independent) to 0.006.

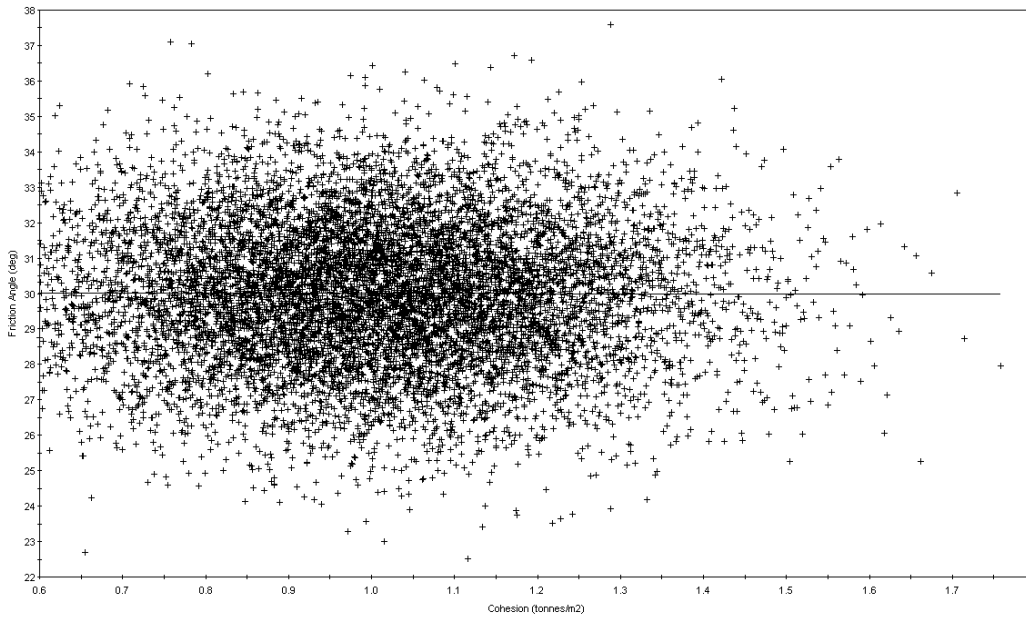

Correlation Coefficient=-0.00316066, alpha=30.0338, beta=-0.0335679

Cohesion vs. Friction Angle: No Correlation

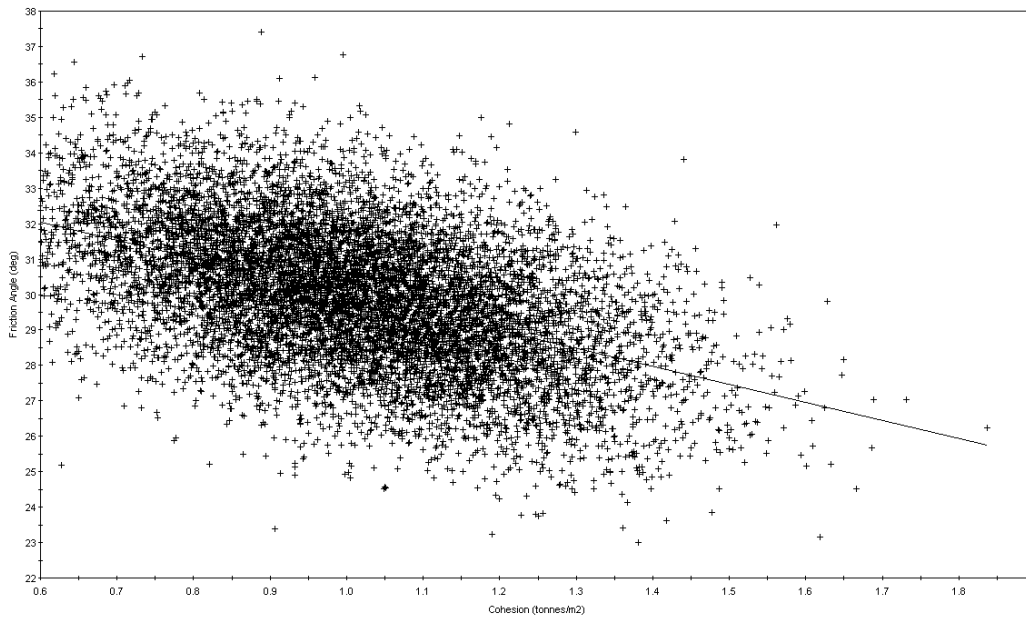

Correlation Coefficient=-0.484036, alpha=35.0923, beta=-5.07962

Cohesion vs. Friction Angle: Correlation Coefficient of -0.5

ROCPLANE SAMPLE PROBLEM #9

Consider the following planar wedge. The upper slope angle of 15 degrees is to be leveled to horizontal in order to build a roadway along the top of the slope.

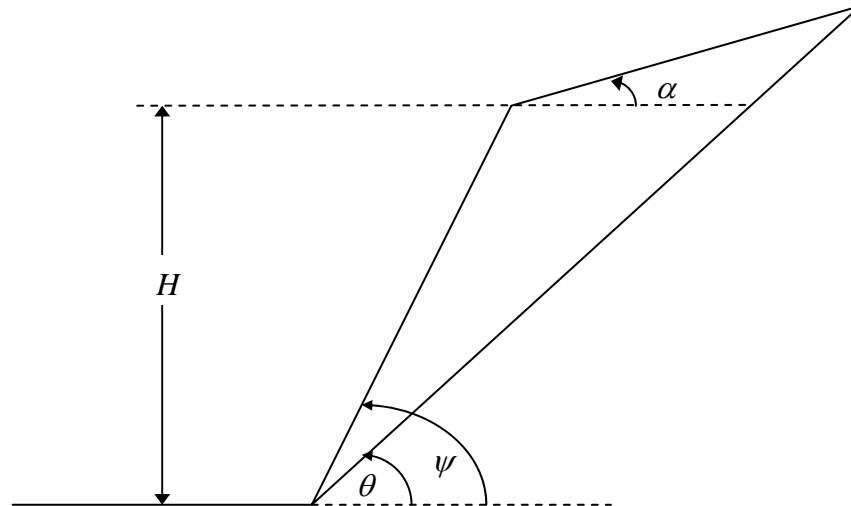

Additional Information:

$$H = 40\text{m}; \psi = 50^\circ; \theta = 30^\circ; c = 10\text{t/m}^2; \phi = 35^\circ; \gamma = 2.7\text{t/m}^3; \alpha = 15^\circ$$

a) Using *RocPlane*, calculate the factor of safety of the wedge before and after the excavation of the upper slope.

SOLUTION:

Using *RocPlane*, the FS = 2.042 for both cases

b) Prove that in general, the safety factor of a planar wedge is independent of the upper slope angle, assuming that the following parameters are constant:

- slope height, H
- slope angle, ψ
- failure plane angle, θ
- failure plane cohesion, c
- failure plane friction angle, ϕ

SOLUTION:

$$FS = \frac{cA + W \cos \theta \tan \phi}{W \sin \theta} \quad (\text{eq. 1})$$

divide numerator and denominator of eq. 1 by W .

$$FS = \frac{\frac{cA}{W} + \cos \theta \tan \phi}{\sin \theta} \quad (\text{eq. 2})$$

If c , ϕ , and θ are all constant, then it can be seen from Eq. 2 that the safety factor (FS) will be constant if the term A/W is constant.

The term A/W is the surface area of the wedge failure plane, divided by the wedge weight.

NOTE:

- i) $A = l \cdot 1 = l$; where l is the length of the wedge failure plane
- ii) $W = \gamma \cdot a \cdot 1$; where γ =rock unit weight, a =area of the wedge triangle
- iii) $\frac{A}{W} = \frac{l}{\gamma \cdot a}$

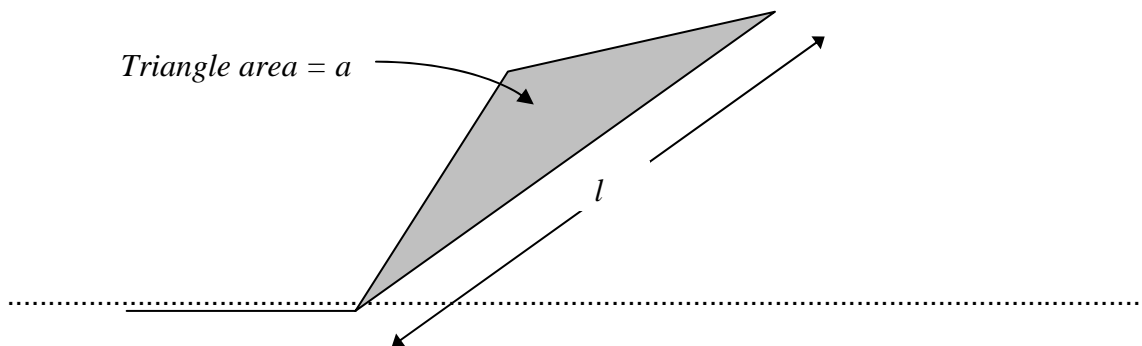

Therefore, to prove that A/W is constant, this is equivalent to proving that l/a (or alternatively, a/l) is constant, since γ , the unit weight of rock, is also a constant.

First, derive the area of the wedge triangle:

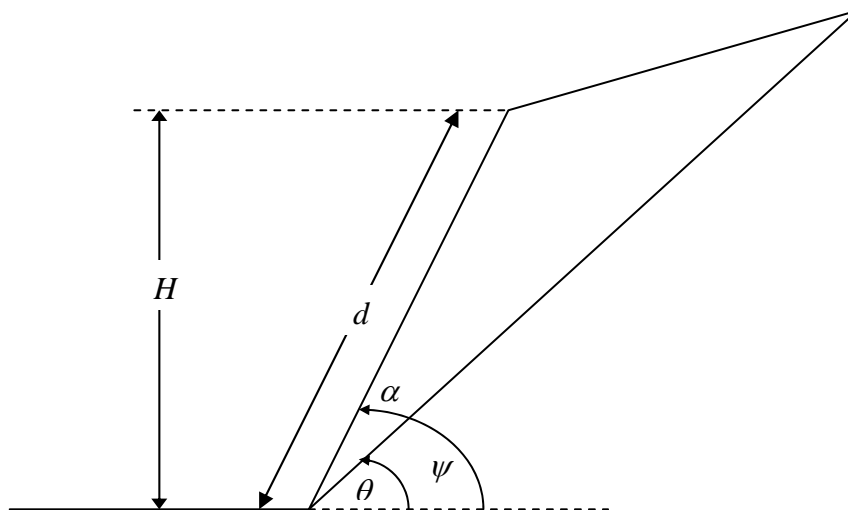

$$\text{Length: } d = \frac{H}{\sin \psi}$$

$$\text{Angle: } \alpha = \psi - \theta$$

$$\text{Triangle area: } a = \frac{1}{2} \cdot d \cdot l \cdot \sin \alpha = \frac{1}{2} \cdot \frac{H}{\sin \psi} \cdot l \cdot \sin(\psi - \theta)$$

$$\therefore \frac{a}{l} = \frac{\frac{1}{2} \cdot \frac{H}{\sin \psi} \cdot l \cdot \sin(\psi - \theta)}{l} = \frac{1}{2} \cdot \frac{H}{\sin \psi} \cdot \sin(\psi - \theta)$$

Since H , ψ , and θ are assumed constant, the ratio a/l is constant, and the factor of safety in eq. 2 is constant.

CONCLUSION:

The FS is independent of the upper slope angle, because the ratio of the wedge area to the failure plane length remains constant, for any orientation of the upper slope angle.

ROCPLANE SAMPLE PROBLEM #10

It is possible to determine the stability of a slope by performing a probabilistic analysis of the variables affecting the factor of safety. When slope properties can be assigned any value from a range of data, the factor of safety must be computed while taking these variations into account. The Point Estimate Method (PEM), first presented by Rosenbleuth [2], is a direct computational procedure that obtains moment estimates for a random variable. As the shape of the probability density function (pdf) is not critical to the analysis, a distribution may be assumed.

Where c and ϕ are the strength parameters, β is the slope angle, and H is the slope height. Specifically, $H = 40\text{ft}$, $\beta = 60^\circ$, $\phi = 30^\circ$, $V(\phi) = 15\%$, $c = 300\text{lb/ft}^2$, $V(c) = 40\%$ and $\gamma = 100\text{lb/ft}^3$.

a) Using the method developed by Rosenbleuth [2], obtain the expected values and the coefficients of variation for the factor of safety for correlation factor (ρ) = -1, 0, +1. What happens to these values as the correlation coefficient increases?

SOLUTION:

Using the PEM developed by Rosenbleuth [2]:

All parameters but ϕ and c will be considered constant.

$$c_+ = c + (V(c) \cdot c) = 300 + 0.4 \cdot 300 = 420$$

$$c_- = c - (V(c) \cdot c) = 300 - 0.4 \cdot 300 = 180$$

$$\phi_+ = \phi + (V(\phi) \cdot \phi) = 35^\circ + 0.15 \cdot 35^\circ = 34.5^\circ$$

$$\phi_- = \phi - (V(\phi) \cdot \phi) = 35^\circ - 0.15 \cdot 35^\circ = 25.5^\circ$$

Summary

c+	420	phi+	34.5
c-	180	phi -	25.5

Calculate the Point-mass Weights for each value of correlation coefficient.

	ρ	-1	0	1
p++, p--	$(1+\rho)/4$	0	0.25	0.5
p+-, p-+	$(1-\rho)/4$	0.5	0.25	0

Using the given equation, calculate the factor of safety for each combination of varying attribute, for each value of correlation coefficient.

Factor of Safety

Factors of safety were determined using RocPlane and the given data.

First Moment

Sample calculations:

$$FS_{++(\rho=-1)} = p_{++(\rho=-1)} \cdot FS(c+, \phi+) = 0 \cdot 2.71553 = 0$$

$$E[FS] = \sum_{(\rho=-1)} FS = 0 + 1.12141 + 1.06886 + 0 = 2.19027$$

FS(ϕ, c)	FS _{i, i}	ρ	$\rho FS_{i, i}$		
			-1.00	0.00	1.00
FS ++	2.71553		0	0.678883	1.357765
FS +-	2.24282		1.12141	0.560705	0
FS -+	2.13772		1.06886	0.53443	0
FS --	1.66501		0	0.416253	0.832505
E[FS] =			2.19027	2.19027	2.19027

Second Moment

Sample Calculations:

$$FS^2_{++(\rho=1)} = (FS_{++(\rho=1)})^2 = 3.08^2 = 9.47$$

$$E[FS^2] = \sum_{(\rho=1)} FS^2 = 0.00 + 0.87 + 1.74 + 0.00 = 2.61$$

FS(ϕ, c)	FS _{i, i} ²	ρ	$\rho FS^2_{i, i}$		
			-1.00	0.00	1.00
FS ++	7.374103		0	1.843526	3.687052
FS +-	5.030242		2.515121	1.25756	0
FS -+	4.569847		2.284923	1.142462	0
FS --	2.772258		0	0.693065	1.386129
E[FS²] =			4.800044	4.936612	5.073181

Expected Values and Coefficient of Variance

Sample Calculations:

$$V[FS] = E[FS^2] - (E[FS])^2 = 4.800044 - (2.19027)^2 = 0.002761503$$

$$\sigma[FS] = \sqrt{V[FS]} = \sqrt{0.002761503} = 0.05255$$

$$V(FS)\% = \frac{\sigma[FS]}{E[FS]} \times 100 = \frac{0.05255}{2.19027} \times 100 = 2.399248$$

	σ [FS]	V[FS]	V(FS) (%)
$\rho = -1$	0.05255	.002761503	2.399248
$\rho = 0$	0.3732691	0.139329785	6.361306
$\rho = +1$	0.52526	0.275898068	23.98152

From these calculations, it can be seen that as the correlation coefficient increases, the expected values and the coefficients of variation also increase.

b) If FS = 1 represents failure, calculate the probability of failure for the results obtained in part (a).

SOLUTION:

Since the first and second moments are calculated, a normal distribution is assumed for the factor of safety.

Sample Calculations:

Standardize values to fit normal curve:

$$z = \frac{E(FS) - FS}{\sigma(FS)} = \frac{2.19027 - 1}{0.3732691} = 3.188771854$$

To find the area under the normal curve which represents the probability that $FS \leq 1$:

$$P(FS \leq 1) = \frac{1}{2} - \Phi(3.19) = \frac{1}{2} - 0.499289 = .000714$$

$$R(\%) = (1 - P(FS \leq 1)) \times 100 = (1 - 0.000714) \times 100 = 99.92855$$

ρ	Probability of Failure	R (%)
-1	0	100
0	0.000714	99.92855
1	0.011724	98.82761

REFERENCES

1. Dr. E. Hoek, 2000, "A slope stability problem in Hong Kong", *Practical Rock Engineering*, pp. 92 - 104.
<http://www.roscience.com/hoek/pdf/Chapter%207%20of%20Rock%20Engineering.pdf>
2. Rosenbleuth, E. (1975*b*): "Point Estimates for Probability Moments," *Proc. Nat. Acad. Sci. USA*, vol.72, no.10.